

Calibration

Kistler takes pride in its control and concern for the integrity and accuracy of our calibration system. Our system is compliant with ANSI/NCSL Z540-1-1994, MIL-STD-45662A, ISO 9001:2000 and now is fully accredited to ISO/IEC 17025. Considerable resources in personnel and equipment have been devoted to the maintenance and management of this system and all primary and working standards used in calibration of our products.

Kistler believes that, not only are you buying a technically superior product, guaranteed to meet or exceed your expectations, but you are also buying a calibration certificate attesting to the performance, accuracy and traceability of your device.

All Kistler products are calibrated using NIST traceable calibration standards, whose reliability and repeatability have been demonstrated through periodic verification and historical data. In fact, Kistler products are used as primary standards in many well known calibration laboratories throughout the world.



Calibration

Charge Amplifier

Calibration Systems Types 8802, 8804



Connection
10-32 neg.

Specifications		Type 8802	Type 8804
Acceleration Range	g	±250	±250
Acceleration Limit	g	±1000	±1000
Threshold	g_{rms}	0,02	0,01
Ref. Voltage Sensivity at 100 Hz, 10 g and 23,9 °C	mV/g	10 ±0,01	10 ±0,01
Frequency Response	Hz	10 ... 10 000	10 ... 10 000
Transverse Sensivity at 100 Hz	pC/s	≤2	≤2
Time Constant	s	1	1
Non-Linearity	%	±0,5	±0,5
Operating Temperature	°C	-21 ... 57	-21 ... 57
Temp. Coeff. of Sensivity	%/°C	-0,04	-0,04
Output Voltage FSO	V	±2,5	±2,5
Ground Isolation	Ω	-	>10 ⁷
Output Impedance	Ω	<15	<15
Power Supply	VAC	115/230	115/230
Mass	Gramm	20	80

Characteristics
This system features unique stability, linearity and repeatability

Applications
System for calibration of sensors. Lab standard or back-to-back calibration transfer

System Components
8802 = 8002/5022
8804 = 8076/5022

Datasheet 8802_000-520
8804_000-521

Reference Shaker Type 8921



Specifications		Type 8921Y26
Frequency	Hz (rads)	159,2 (1000)
Acceleration rms, ±3%	g	1
Velocity rms, ±3%	mm/sec	10
Displacement rms, ±3%	µm	10
Max. Load	gram	300
Operating Temp.	°C	10 ... 40
Power Supply	mA	300
	VDC	12
Battery	type	built-in rechargeable
Mass	kg	2
Dimensions	mm	76,2 H x 107 W x 178 D

Characteristics
Test measurement system integrity, convenient self-contained and portable, rechargeable battery, tests sensors up to 300 g of weight, CE compliant

Applications
The 8921 reference shaker can be used to confirm the sensitivity of acceleration, velocity, and displacement sensors

Accessories
10-32 to M5 stud: Type 8451
1/4 -28 to M5 stud: Type 8453

Specify Version
8921Y26: supplied with 115 VAC battery charger
8921: supplied with 230 VAC battery charger

Datasheet 8921_000-362

Calibration

Charge Amplifier

Quartz Compression Laboratory Primary Standard Accelerometers Type 8002K...

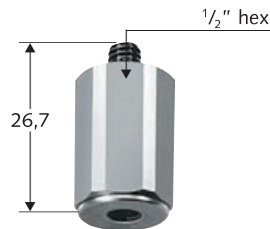

Specifications		Type 8002K
Range	g	±1000
Sensitivity	pC/g	-1,0
Frequency Response, -1 ... 5%	Hz	≈0 ... 6000
Threshold nom.	g_{rms}	0,02
Transverse Sensitivity max.	%	2
Non-Linearity	%FSO	±0,5
Temp. Coeff. of Sensitivity	%/°C	-0,03
Operating Temperature	°C	-70 ... 120
Housing/Base	type	St. Stl.
Sealing	type	Epoxy
Mass	gram	20
Sensing Element	type	Quartz/compression

Measuring direction a_z
 Connection 10-32 neg.

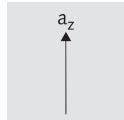

Characteristics
 High impedance, charge mode, quartz stability and repeatability, wide operating temperature range.

Applications
 Used with 5022 to form a complete calibration primary standard. Long duration shock pulses or high frequency vibrations even in cryogenic or high temperature environments.

Accessories
 Mounting Stud: Type 8402
 Cable: 1631C...
 Charge Amplifier: 5022

Datasheet 8002_000-205

Vibration Standard Quartz Accelerometer Type 8076K

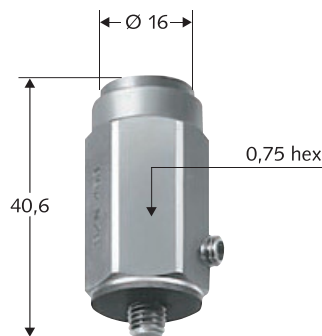

Specifications		Type 8076K
Range	g	±1000
Sensitivity	pC/g	1
Frequency Response, ±4%	Hz	0,5 ... 5 000
Threshold nom.	g_{rms}	0,01
Transverse Sensitivity max.	%	2
Non-Linearity	%FSO	±0.5
Temp. Coeff. of Sensitivity	%/°C	0,02
Operating Temperature	°C	-20 ... 65
Housing/Base	type	St. Stl.
Sealing	type	Epoxy
Mass	gram	80
Sensing Element	type	Quartz/compression

Measuring direction a_z
 Connection 10-32 neg.

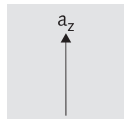

Characteristics
 High impedance charge mode, quartz accuracy and stability, rugged design, low base strain sensitivity, ground isolated. Low mass loading

Applications
 Used with 5022 to form a complete back-to-back calibration transfer standard. High precision laboratory accelerometer

Accessories
 Mounting Stud: Type 8410
 Cable: 1631C...
 Charge Amplifier: 5022

Datasheet 8076K_000-210